

COPYRIGHT © GOULAS + ASSOCIATES, INC. ALL DRAWINGS, SPECIFICATIONS AND DESIGNS APPEARING HEREIN CONSTITUTE THE ORIGINAL AND UNPUBLISHED WORK OF THE ARCHITECT, DESIGNER AND HIS/HER ASSOCIATES, AND THE SAME MAY NOT BE DUPLICATED, USED OR DISCLOSED WITHOUT THE EXPRESS WRITTEN CONSENT OF THE ARCHITECT/DESIGNER.

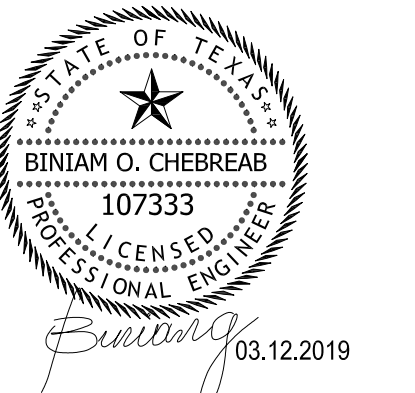

**Project Information:**

**Consultants:**

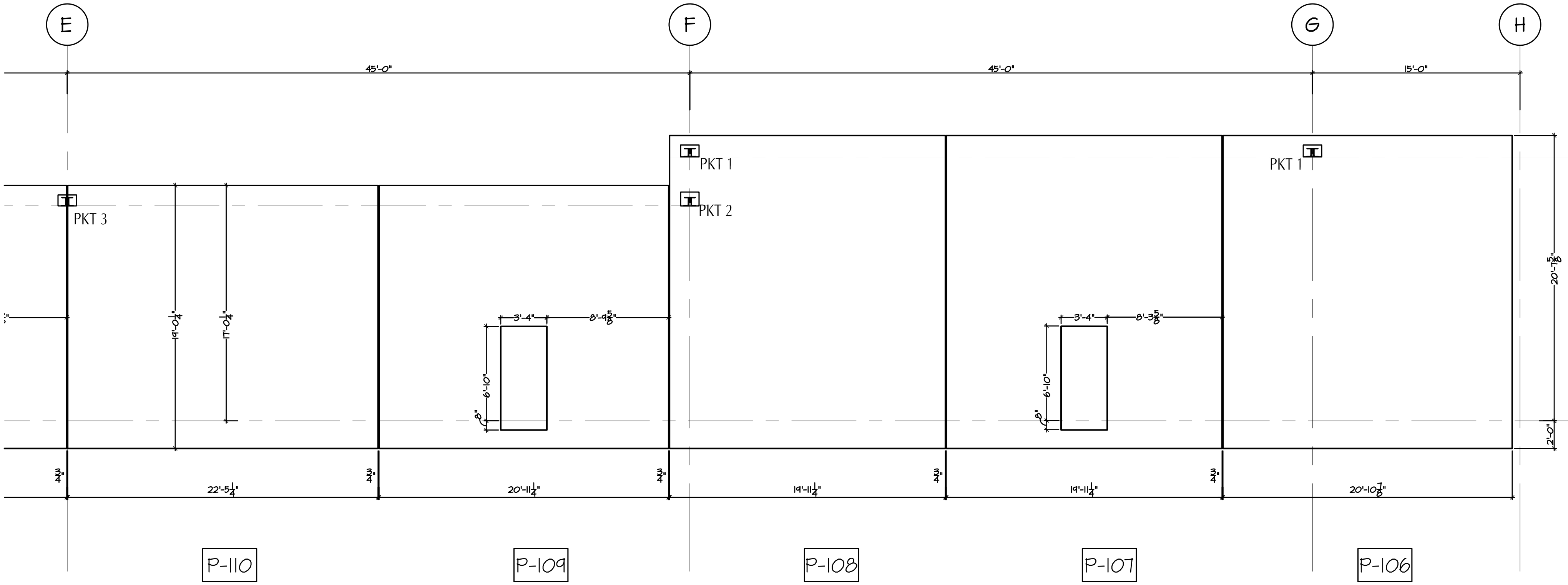
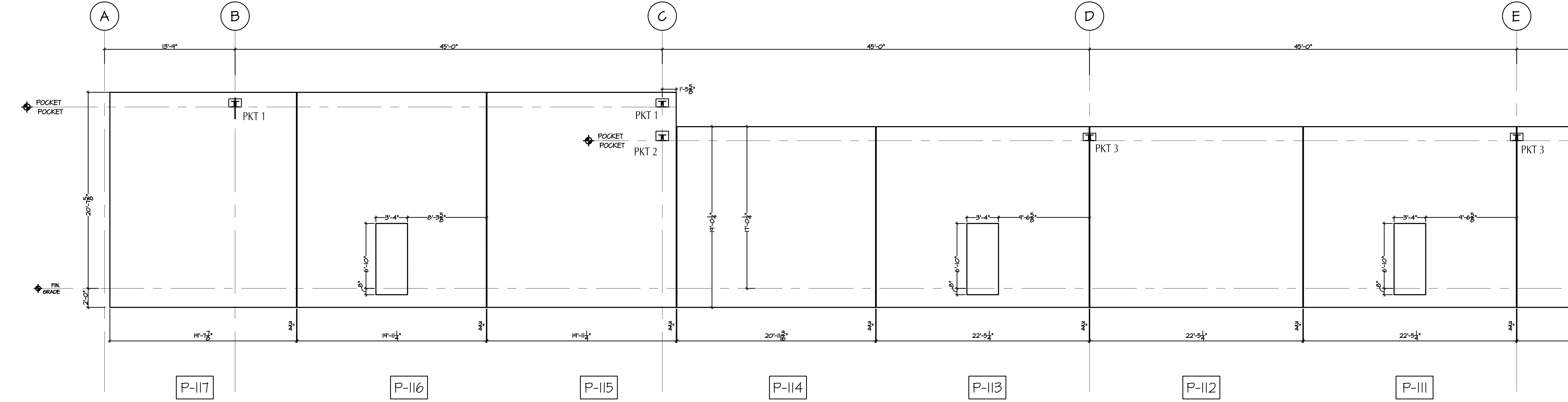
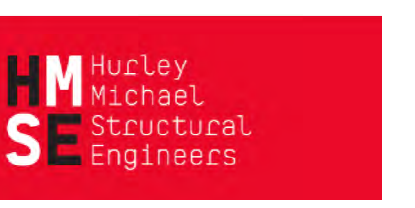

**SHOPS ON GOSLING  
 RETAIL CENTER  
 SHELL BUILDING DEVELOPMENT  
 24909 GOSLING ROAD  
 SPRING, TEXAS 77389**

**Sheet Title:**

**P/C PANEL  
 ELEVATIONS**

**Issue:**

**CD/PERMIT  
 Issue Date:**

12 MARCH 2019

**Revision Date:**

**Sheet:**

**S5.3**